

THIS DRAWING IS UNPUBLISHED. RELEASED FOR PUBLICATION ,19 .
 © COPYRIGHT 19 BY AMP INCORPORATED. ALL RIGHTS RESERVED.

LOC	DIST	REVISIONS			
P	LTR	DESCRIPTION	DATE	DWN	APVD
AF	50	H	REDRAWN PER 0L10-0037-96	8/9/96	JR PD

- 1 CONTINUOUS STRIP ON REELS.
- 2 WIRE SIZE IS [#22-#16] AWG.
- 3 MATING TAB THK TO BE 0.508±0.025 [.020±.001].

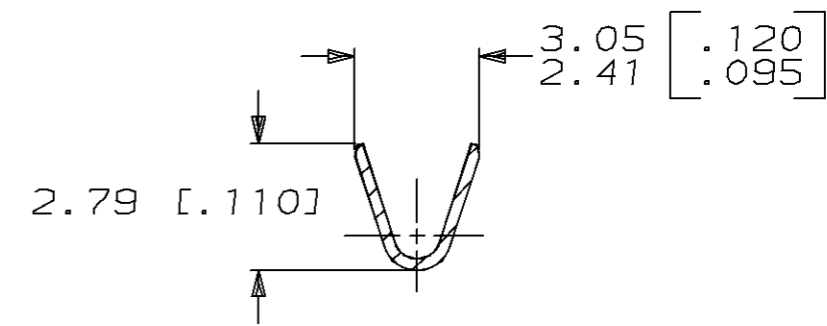
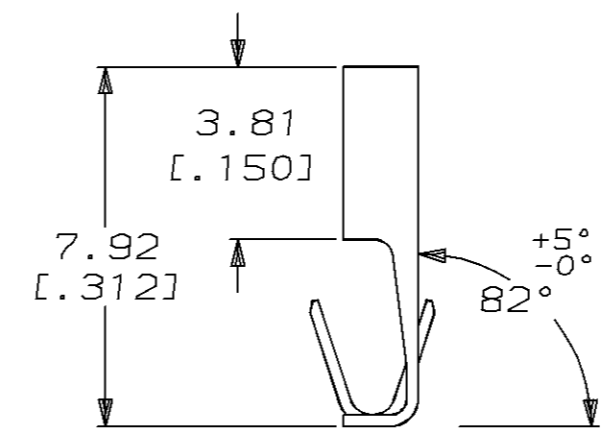
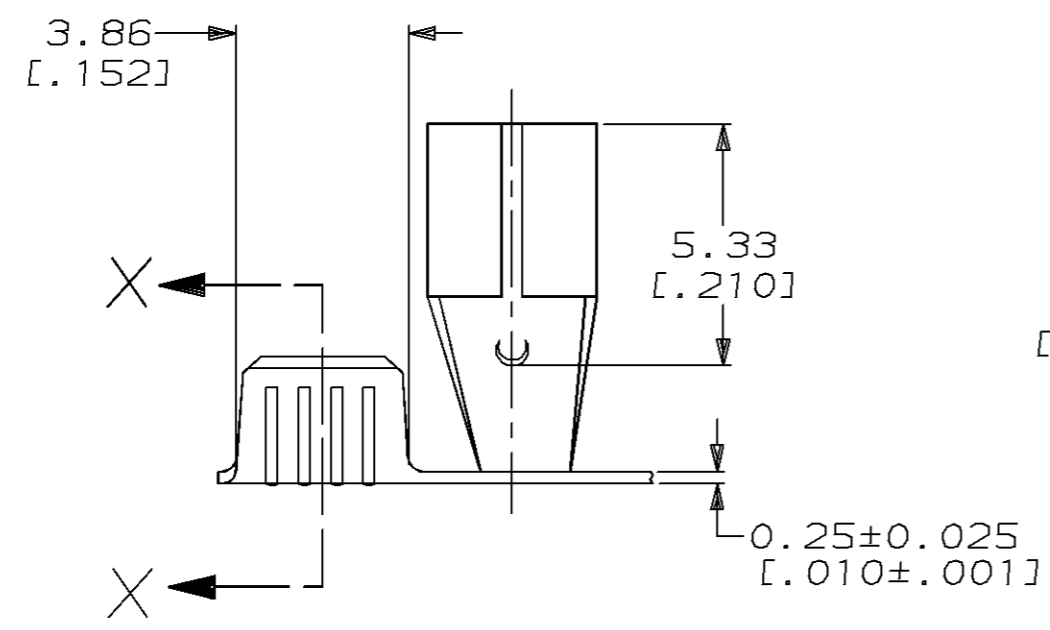
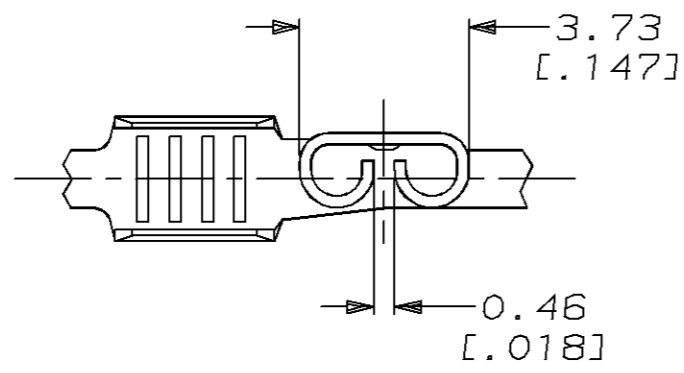

62321-1
PART NO.

THIS DRAWING IS A CONTROLLED DOCUMENT.		DWN	JR RUTH	7/30/96	AMP AMP Incorporated Harrisburg, PA 17105-3608
DIMENSIONS: MM [INCHES]		CHK	P FORTNEY	7/30/96	
TOLERANCES UNLESS OTHERWISE SPECIFIED:		APVD	P DESANTIS	7/30/96	NAME
0 PLC ±-		PRODUCT SPEC	RECEPTACLE, FASTON, FLAG, 2.79 [.110] SERIES		
1 PLC ±-		APPLICATION SPEC	SIZE		
2 PLC ±0.25 [.010]		WEIGHT	A3		
3 PLC ±-		CUSTOMER DRAWING	CAGE CODE	00779	
4 PLC ±-			DRAWING NO	C-62321	
ANGLES ±-			SCALE	6:1	SHEET 1 OF 1
MATERIAL	H04 BRASS	FINISH	PRE-TIN	REV	H